

ECOTHERMTM

Swimming Pools

Jump in! The Water's Warm



Installation Manual

Residential Onground or
Semi-Inground Round Swimming Pool

IMPORTANT SAFETY INFORMATION

Enclosed in the liner box is the safety envelope. The safety stickers must be installed as per instructions. Failure to properly install warning labels will void warranty. Alert all visitors and family of the risks associated with jumping and/or diving and point out all warning labels supplied. Failure to mount these safety labels may subject you to substantial liability in case of injury.

Your pool is designed for years of pleasurable, safe family fun. However, when used incorrectly, a swimming pool can be dangerous. To insure your pool is used safely you must observe the following safety precautions:

1. Do not dive, do not jump, no rough play, no running or pushing.
2. Be sure to install all safety labels provided with your pool according to the safety instructions.
3. Keep a 50' safety rope and flotation buoy with an outside diameter of 15" accessible prominently by pool.
4. Post near all entrances to the pool area a list of telephone numbers for the following:
 - a. Local police
 - b. Local fire department
 - c. Local rescue unit
 - d. Local ambulance service
 - e. Local hospital
 - f. 911 emergency number, if available
5. Provide fencing or an enclosure which is independent of the house as a closure around the entire pool area. The fencing must be made of durable material, a minimum of 4' high from ground level and with closures with selflatching locks to make the pool inaccessible to toddlers and uninvited guests. Make sure the gate is always closed. Be sure to follow local building code requirements for load capacity and fencing if using an aftermarket or home built deck.
6. Check with your local town or municipality in regard to obtaining a building permit and/or an electrical permit. The installer shall follow the regulations for set backs, barriers, devices and other conditions.
7. All electrical outlet connections should be a minimum of 5' from the outside perimeter of the wall of the pool. From 5'-10' there should be either a fixed connection (outlet box) or twist lock connection with a GFCI. Connect power cords to a 3-wire grounding-type outlet only.
8. Severe electrical shock could result if you install your pump or filter on a deck. They could fall into the water causing severe shock or electrocution. Do not install on a deck or other surface at, above or slightly below the top ledge of the pool, within 5 feet of pool water edge.
9. Do not sit, stand or climb on the pump and filter or any part of the pool structure. Components such as the filtration system, pumps and heater must be positioned so as to prevent their being used as a means of access to the pool by young children.
10. Never drink alcoholic beverages or use any intoxicants which could hinder your judgment and reflexes.
11. Never use the pool alone. All children must be supervised continuously.
12. Do not use pool if bottom is not clearly visible. At night, sufficient lighting must be available. It is the pool owners' sole responsibility to provide adequate lighting for the pool bottom, safety signs and walkways, which exceeds minimum standards of the IES of North America.
13. Be sure that all toys, chairs and tables or similar objects that a young child could climb on be at least 4' from the pool.
14. Do not use pool during electrical or rain storms.
15. See available Association of Spa and Pool Professionals (APSP) publications for more tips on pool safety

INTRODUCTION

The Installation of the Ecotherm™ Round pool is not hard, nor complicated. Although installation conditions might differ from this guide, it is important to consult with the manufacturer before making any changes that might disturb the integrity of the pool. Failure to follow these instructions will void all warranties. Read and follow all manufacturers' instructions including accessories such as pumps, filters, skimmers prior to starting.

Before you start, check your packing list to confirm that you have the correct number of parts and components. The manufacturer reserves the right to revise, change or modify construction of its pools. See packing list for pool components included for your pool. If there are any missing or damaged components, please contact your retailer for replacement.

While all Ecotherm Pools™ are designed to meet or exceed industry recommended safety standards (ANSI/APSP-4 and 5 American National Standards for Residential Swimming Pools), special attention must be paid to all installation procedures that the installer performs and controls. Spend time to ensure that the entire pool framework is perfectly level and square. Unlevel pools place extreme pressures on the pool walls. A pool cove must also be installed. This keeps the pool liner from creeping out from under the pool wall. Be sure to follow these instructions. Improperly installed pools can rupture, allowing thousands of gallons of water to rush out causing extensive property damage and injury to anyone in its path. As with any major home project, a homeowner is responsible for following all local laws, ordinances and codes. Electrical grounding of swimming pool is required. National and local codes must be followed. A checklist is provided below as a guide for these considerations.

✓ HOMEOWNER CHECKLIST	
<input type="checkbox"/>	Obtain building permit if required.
<input type="checkbox"/>	Local building and zoning requirements
<input type="checkbox"/>	Electrical and Grounding requirements
<input type="checkbox"/>	Have Ground Tested for Stray Electricity
<input type="checkbox"/>	Proper Backfill and Drainage
<input type="checkbox"/>	Fencing requirements
<input type="checkbox"/>	Backwash (waste water) requirements
<input type="checkbox"/>	Check availability of utilities.
<input type="checkbox"/>	Call before you dig (www.digsafe.com)
NOTES:	

With proper installation, care and maintenance, this Ecotherm™ Residential Swimming Pool will provide a lifetime of fun and relaxation for the homeowner.

Ecotherm Pools™ offers a non-prorated, lifetime guarantee on the entire pool against manufacturing defects. Walls, structural supports and channels are guaranteed against defects due to faulty workmanship or manufacturing for as long as you own your home. Compare our warranty with any other pool. Engineering, innovation and efficiency make the difference.

TOOLS AND MATERIALS NEEDED

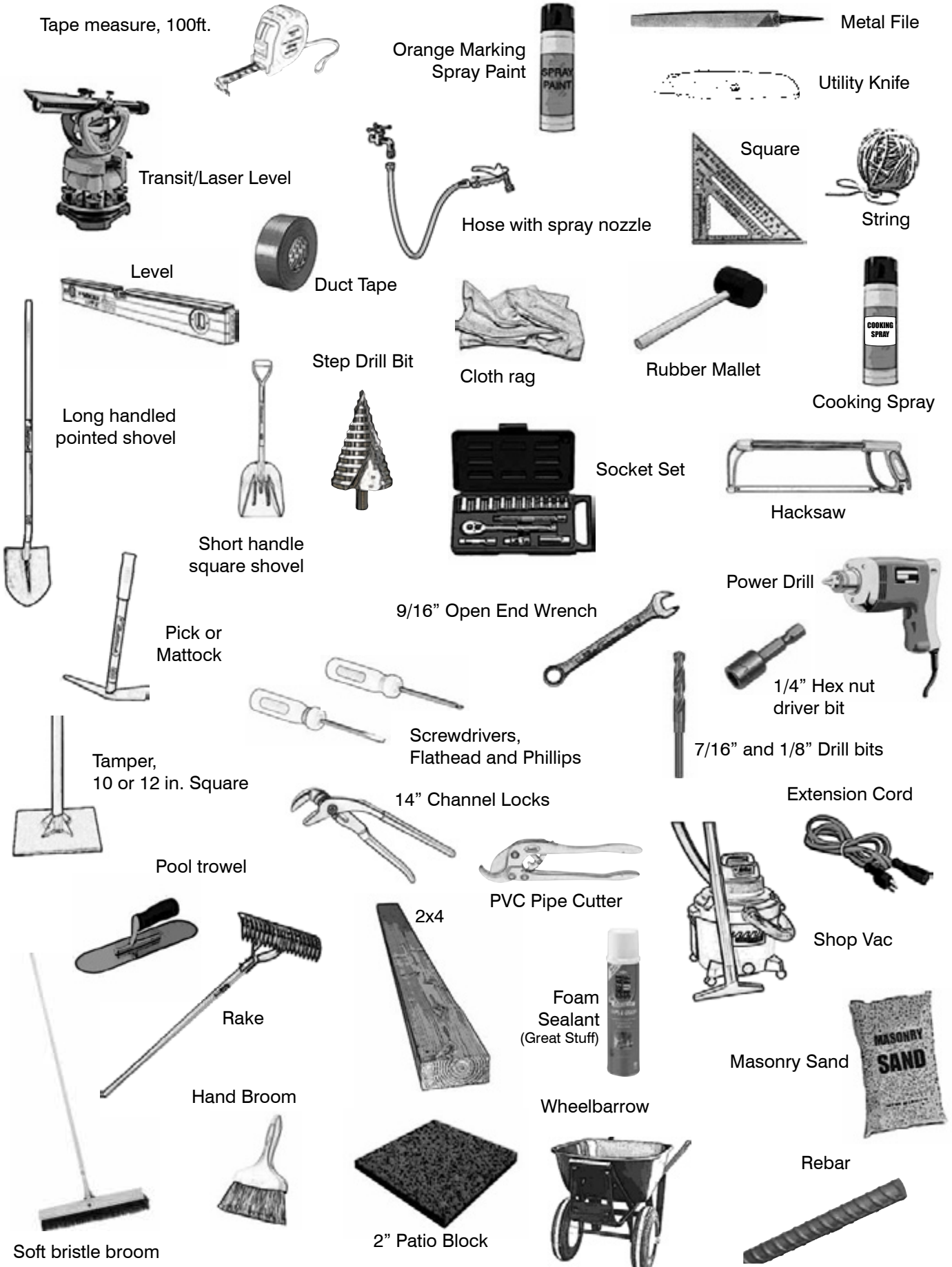

IMPORTANT: BEFORE YOU BEGIN

The selection and preparation of the pool site is your responsibility. The manufacturer can only suggest the proper techniques, indicate the important considerations and emphasize the precautions and cannot be held responsible for damages to your pool that may result from failure to carefully follow all pool specifications.

All Ecotherm Pools™ components are engineered to provide a precise fit. It is very important to handle all components with care. Prior to assembly, all pool components should be free of sand, mud, dirt and debris of any kind.

IMPORTANT: DO NOT ALLOW SPLINES OR COMPRESSION SEAMS TO COME IN CONTACT WITH SAND OR OTHER DEBRIS AS THIS WILL CAUSE DIFFICULTY IN INSTALLATION.

We recommend a small broom or shop-vac to maintain a clean track system throughout the installation process. In addition we recommend a damp cloth be available in the event that any dirt or debris finds its way to the component surfaces.

POOL COMPONENTS CHECKLIST							
Component	16'	18'	21'	24'	27'	30'	33'
Panels	8	8	10	10	10	14	14
Anchor Plates	8	8	10	10	10	12	14
Coping	8	8	10	10	10	12	14
White Cap Screws	50	50	50	50	50	100	100
Coping Clips	8	8	10	10	10	12	14
Splines	16	16	20	20	20	24	28
Bolts ($\frac{3}{8}$ "x 2 $\frac{1}{2}$ ")	16	16	20	20	20	24	28
Skimmer w/ Mounting Kit	1	1	1	1	1	1	1
Return Fitting	1	1	1	1	1	1	1
Vinyl Liner	1	1	1	1	1	1	1

Note: If any portion of your Ecotherm™ Pool is more than 26" inground please refer to the inground installation instructions starting on page 14.

SELECTING POOL LOCATION

The selection and preparation of the pool site is your responsibility. The distributor can only suggest the proper techniques, indicate the important considerations and emphasize the precautions and cannot be held responsible for damages to your pool that may result from failure to carefully follow all pool specifications.

1. The surface on which your pool will stand must be absolutely level and solid. This condition should extend 2 feet beyond the actual pool area. The best surface is bare solid earth free from stones, roots and other sharp objects.

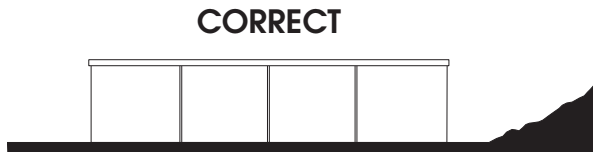

2. Allow plenty of play area around the pool. Fit the location into your landscaping plans.
3. The pool site must be accessible to electrical and water supply and should allow for disposal of great quantities of water when the pool is drained. All electric outlets within 10' must be GFI protected.

5. Do not set up your pool in hilly areas or areas with poor drainage. For Semi-Inground and Inground Installations: The site of installation must accommodate an efficient drainage system to minimize the impact of heavy rain and high ground water conditions.



4. When installing your pool on a solid level surface, it is imperative that you protect your pool and liner from chemicals and other foreign matter contained in the surface. Do not install your pool on peat moss, tar paper, roots, sticks, gravel or chemically treated or contaminated soil not approved for pool use. Any or all of these surfaces can ruin your pool and liner and will void your warranty. To prevent stones or other foreign material from damaging the liner it is recommended to build a 2" to 3" base of clean washed masonry sand or other suitable base material inside the entire pool.

5. If ants or termites are prevalent in your area, have soil treated with insecticides and allow sufficient time for them to dissipate before continuing with pool installation.



6. Do not set up your pool under trees or under overhead wires.
7. Do not set up your pool near any existing structure such as your house, garage, etc., as this condition may compel diving or jumping into your pool which could result in permanent injury or death. You must check with your local municipality for all appropriate ordinances and regulations.

8. Do not set up your pool on or near any septic system or underground utilities.

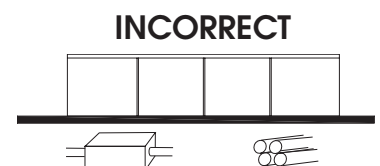

PREPARING THE POOL SITE

Once you have chosen an appropriate location for your pool based on the criteria specified above, determine the pool circumference by putting a stake in the ground at the center of the location desired and with a line equal in length to the radius of the pool ($\frac{1}{2}$ the pool size) plus 12", mark off the circumference with a sharp object, lawn edger, spray paint, etc. **(fig. A)**

After all of the sod has been removed, you must make the pool area absolutely level as measured by a transit or level. Find the lowest spot within the pool area and level the ground to that lowest spot. **(fig. B)** Do not add dirt to the low areas. It is the high areas that must be dug away. The perimeter of the pool must be a solid foundation to prevent the pool from settling into dirt that is loosened by rain and water splashing over the side. Once again, clean the area of all sharp objects, including roots and rocks that could later effect your swimming pool.

For Site Preparation instructions for Inground installation, see page 14.

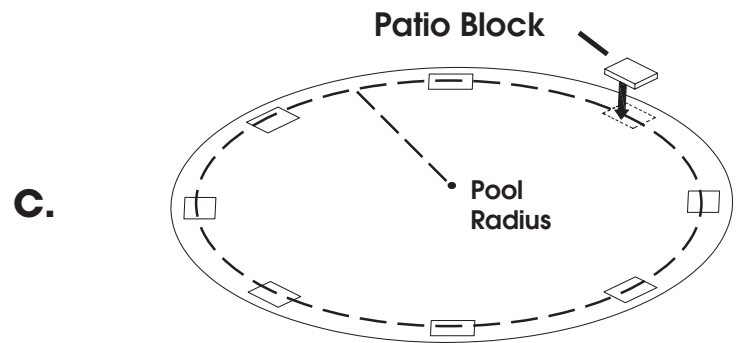
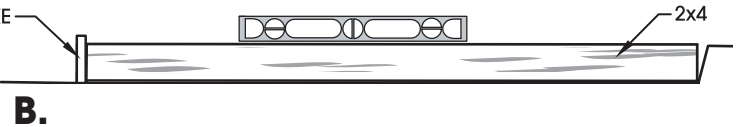
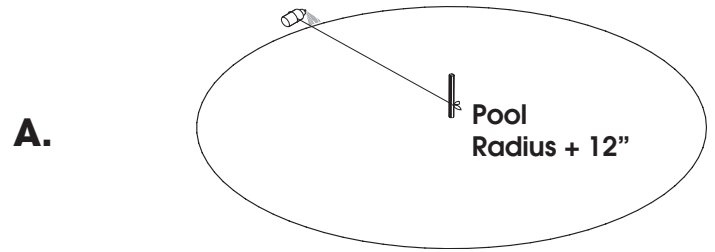

PATIO BLOCK INSTALLATION

Once the ground is prepared, begin installing 2"x 8"x 16" patio blocks. **(fig. C)** The patio blocks should be installed at the perimeter line of the pool ($\frac{1}{2}$ the pool size from the center stake) and at intervals corresponding to the number of panels associated with the size of the pool. Please see chart for appropriate spacing.

Sink each patio block into the prepared ground making sure that each block is level in all directions (side to side as well as front to back). Repeat this step around the perimeter of the pool area making the tops of all blocks level with the ground. Do not install the blocks on loose sifted soil or sand. All patio blocks must be flush with the ground, solid and level with each other in all directions. Once all of the patio blocks are installed, place an anchor plate on each patio block. **(fig. D)** The anchor plates will be used to provide a level platform for wall installation.

Pool Size	Patio Block Intervals	Qty Needed
16'	6' 1 $\frac{1}{2}$ "	8
18'	6' 10 $\frac{5}{8}$ "	8
21'	6' 5 $\frac{7}{8}$ "	10
24'	7' 5"	10
27'	8' 4 $\frac{1}{8}$ "	10
30'	7' 9 $\frac{1}{8}$ "	12
33'	7' 4 $\frac{1}{8}$ "	14

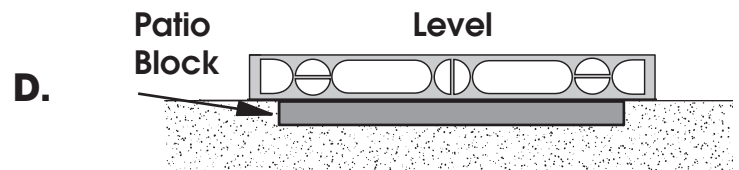

WALL INSTALLATION

Locate the wall panel that is cut for the skimmer and return fitting. The location for the panel should be adjacent to the electrical supply and provide ease of access once the pool is installed.

Place an anchor plate centered on a patio block. Place 2 wall panels so they meet on the center of the anchor plate. **(fig. E)** Please be aware that each compression seam should be flush before attempting to insert the splines. **(fig. G)** Splines are designed to slide freely into place when inserted properly into level panels. Gently shaking panels can help ease insertion of some splines.

Note: If wall panels are not level it will be hard to drop splines. Use cooking oil or food spray as lubricant on the first 4-6" of the splines. Do not use petroleum based lubricants (WD-40).

Hard downward pressure or hammering causes metal burrs and jams the spline into the compression seam. If a spline does not install easily, leave it and go to the next one or next panel. Aligning the next panel will most frequently align the previous one as well.

Duplicate this process with the remaining wall panels, stopping before installing the final wall panel. At this time you need to bring in the sand through this opening to prepare the bottom of the pool.

With the anchor plate centered under the seam, drill $\frac{7}{16}$ " holes through the bottom of the pool panels using the predrilled holes in the anchor plates as a guide. Secure with 2 $\frac{1}{2}$ " bolts and nuts. Make sure the panels are securely in the anchor plates and even at the top before drilling. This will create a bolted pool frame for bonding, if needed. Check with local codes for requirements.

IMPORTANT: Do not drill or install anchor plate bolts until entire wall is constructed.

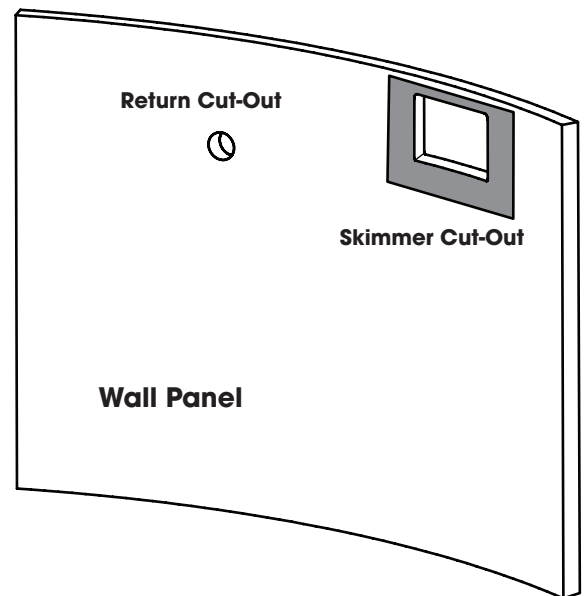
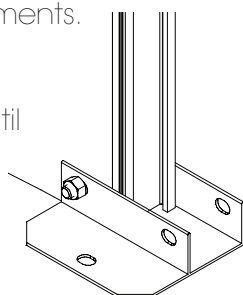

E.

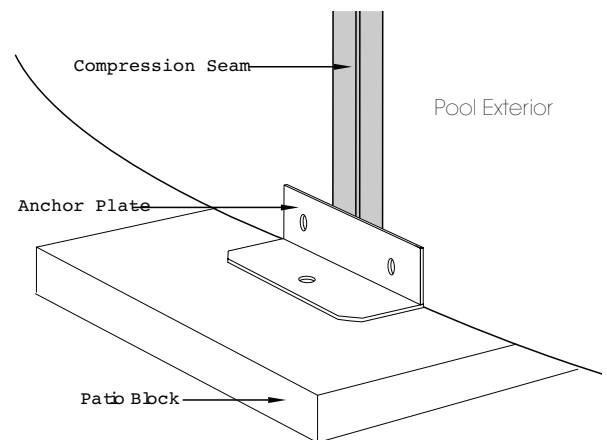

G.

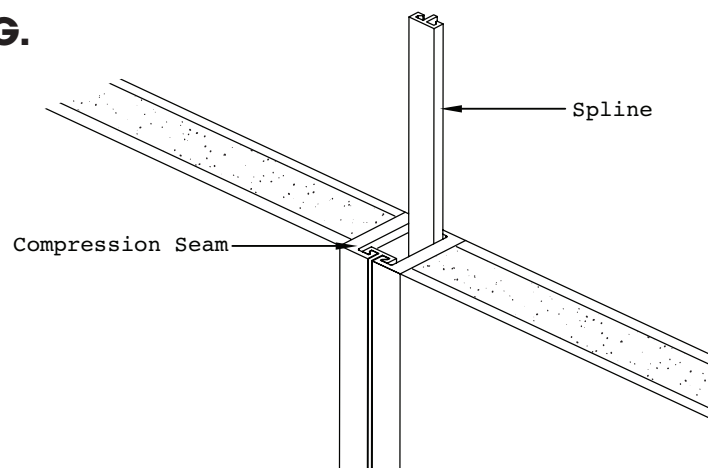

SKIMMER ASSEMBLY

Install the rubber sandwich gasket on the gray mounting plate, making sure the gasket straddles both sides of the mounting plate. **(fig. I)**

Place the gray mounting plate with gaskets on the pool interior side of the panel cut-out. Insert the white plate with throat on the exterior of the panel, through the pool wall. Secure the assembly with 2 1/4" countersink bolts and T-nuts loosely through four pre drilled corner holes in the gray mounting plate, the wall panel and the white mounting plate. **(fig. J)**

Use the fifth bolt and T-nut at the bottom center hole in the mounting assembly and tighten firmly. Do not over tighten. **(fig. K)**

Slip skimmer body through the white plate to the gasket on the gray plate. **(fig. L)** Secure tightly with two pan head screws (different style screws in the skimmer hardware bag) from the water side through the gaskets and gray plate into the skimmer body center hole on each side. **(fig. M)**

Tighten the four corner bolts, firm, do not over tighten. The skimmer faceplate is attached after the liner is installed.

For Skimmer Assembly instructions for Inground installation, see page 20.

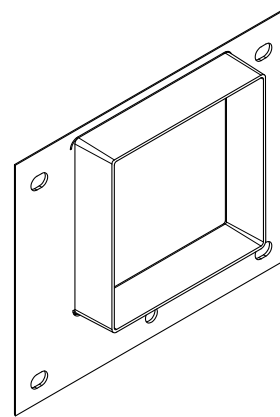

Outside White Mounting Plate w/ Throat

Note: this eliminates the need for the U-shaped Foam Insert previously provided

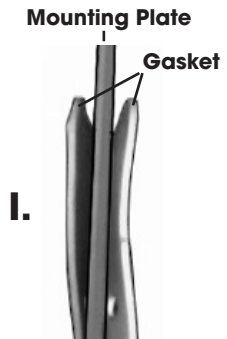

I.

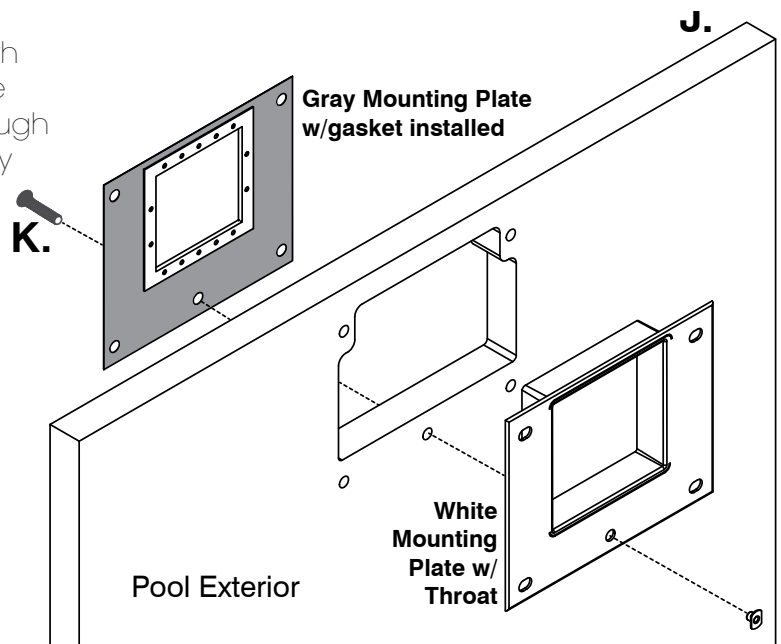

J.

K.

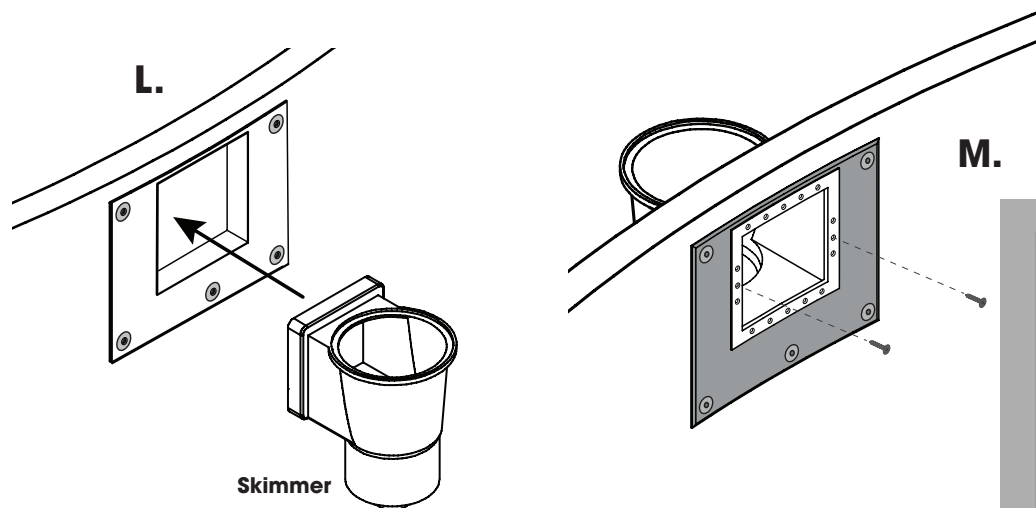

L.

M.

Skimmer

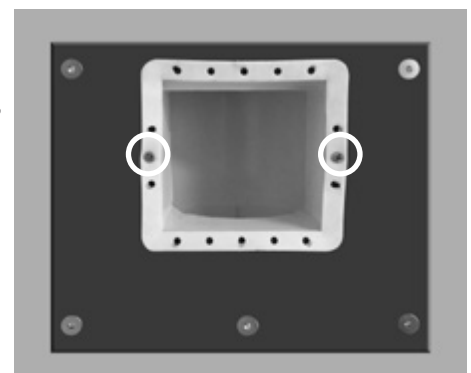

Patent Nos: 9,890,547/D837,471/D830,012/10,138,645. Other Patents Pending.

RETURN FITTING ASSEMBLY

The return fitting kit includes four parts: inlet fitting, 2 inlet plate and back nut.

Install the inlet fitting into the pre-cut hole, slide the inlet plate over the exposed threads on the pool interior and exterior, then thread the back nut onto the fitting. **DO NOT OVERTIGHTEN.**

For additional return fittings, drill 3" hole (with 3" hole saw), 12" down from top of panel. Edges will be sharp but not in contact with liner or hands once wall fitting has been installed. Install return wall fitting per directions, firmly. Do not over tighten.

Note: For the Ecotherm™ LED light, drill hole 14" down from top of panel. Installation is identical to return fitting.

The return faceplates are attached after the liner is installed.

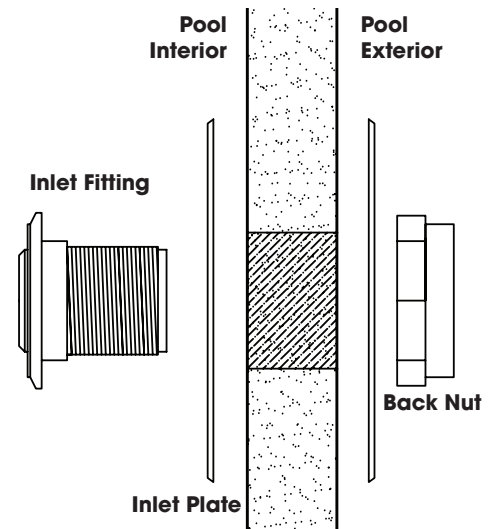

PREPARING POOL FLOOR & COVE

Bring the required amount of clean and washed masonry sand into the interior of pool area. Refer to the chart for the required amount.

The Pool interior must be prepared to provide a smooth surface and protection for the vinyl liner. Check inside the pool area for debris, stones, sharp objects, etc and remove them. Using the masonry sand, build a pool cove 4" to 6" high inside the wall along the entire circumference of the pool. **(fig. N)** This will prevent the liner from creeping under the wall. **This step is not optional and must be done.**

Spread the remaining sand equally across the bottom of the pool. This gives you a 2" sand base. After the cove and base are in place, dampen, rake and tamp the entire pool area. Make sure that no sand is allowed to remain on the wall above the cove. This could cause pinholes in your liner.

Once bottom and pool cove are set, install final panel

Pool Size	Sand Amt (cubic yds)
16'	1.8
18'	2
21'	3
24'	3.5
27'	4.5
30'	5.5
33'	6.5

1 yard masonry sand = appx 1.5 tons

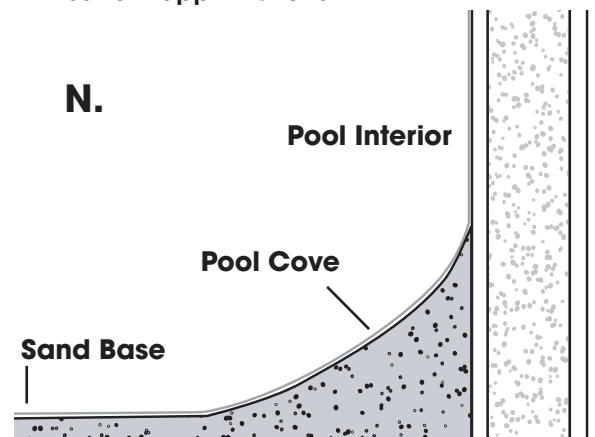

INSTALLING PLASTIC COPING

The plastic coping is installed by simply placing coping lengths over the pool wall and securing with screws on the exterior of the pool.

Place all coping lengths around pool, leaving a 1" gap between each length. The coping gap should be offset from a wall joint.

Once all of the coping has been placed, secure the coping to the pool wall with sheet metal screws provided. **THIS STEP CANNOT BE SKIPPED.**

Included are 5 sheet metal screws for each full size coping length. For Premium 4" coping, 2 additional screws per coping length are included to be placed on the inside of the coping and covered by duct tape. The screws, placed at the appropriate intervals, are essential to the secure installation and long term durability of the coping. The screw spacing should be as follows:

- One screw approximately 2-3" from each end.
- One screw in the middle of the coping length.
- One screw half way between center and each end screw.

Using a 1/8" drill bit, drill through the plastic coping and exterior pool wall while pressing down firmly on the coping on top of pool wall. Using a Phillips screwdriver, hand tighten each screw. **DO NOT OVER TIGHTEN.**

The beaded vinyl liner with the weight of the water will draw coping into place and level on the interior of the pool wall. After the liner is in place, install coping clips by snapping over gaps between coping. **DO NOT SCREW IN COPING CLIPS.**

For RCR and Paver inground coping installation instructions see page 18-19.

Standard 2" Coping

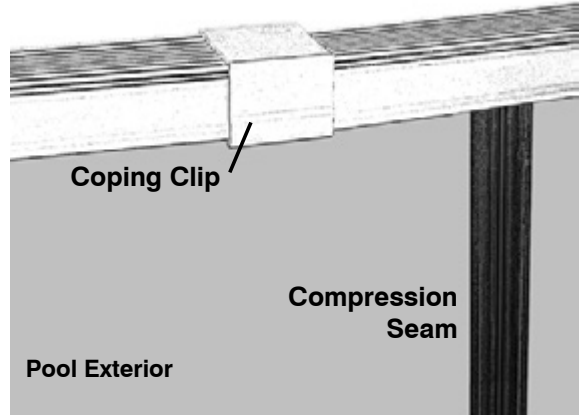

Premium 4" Coping

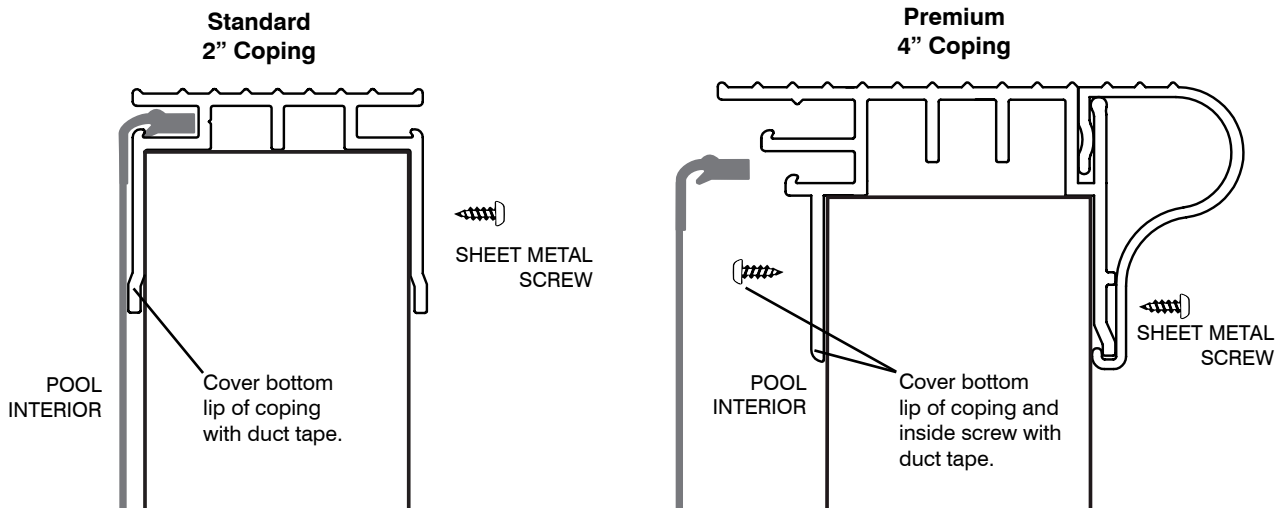
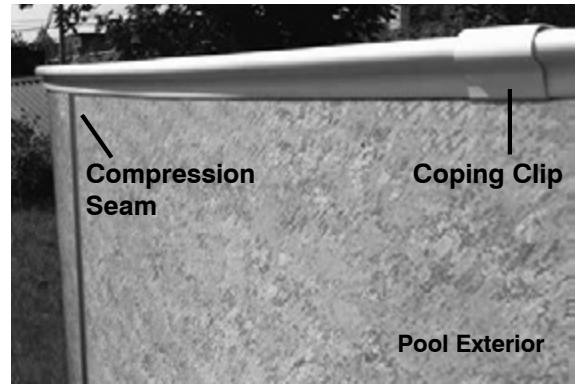

INSTALLING LINER

Prior to installing liner, tape all joints, including coping and compression seams, with Gorilla Tape®. Clear all sticks and sharp objects from an area near the pool that is as large as the pool itself. Remove the liner from its carton in the area you have prepared. Unfold and open the liner. Refold the liner so that it can easily be carried to the pool and unfold from the outside of the pool. Check to make sure the sand in the pool is level and that there are no sharp objects in pool.

Place the liner into the pool while holding onto the top of the wall section of the liner. Snap the bead of the liner into the bead receiver track around the entire pool.

(Be sure to insert liner bead in bottom track of Premium 4" coping as shown at right)

Gently pull on the liner and use a soft bristle broom to remove as many wrinkles as possible on the bottom of the pool. Start filling the pool slowly with water. Continue pulling gently and working the liner with a broom as needed. Some wrinkling of the liner may be evident and in no way affects the structural strength of your pool. You can continue to work out the wrinkles as needed by pulling gently on the liner or by using a broom.

TIP: To help in removing stubborn wrinkles, a shop vacuum may be used to suck the air out from behind the liner. Attach shop vac to skimmer outlet and seal with duct tape. Seal all other openings with duct tape as well. Turn on vac and run till wrinkles are removed. Once the wrinkles are gone, begin filling with water. After 6" of water is in the pool, turn off and remove the shop vac

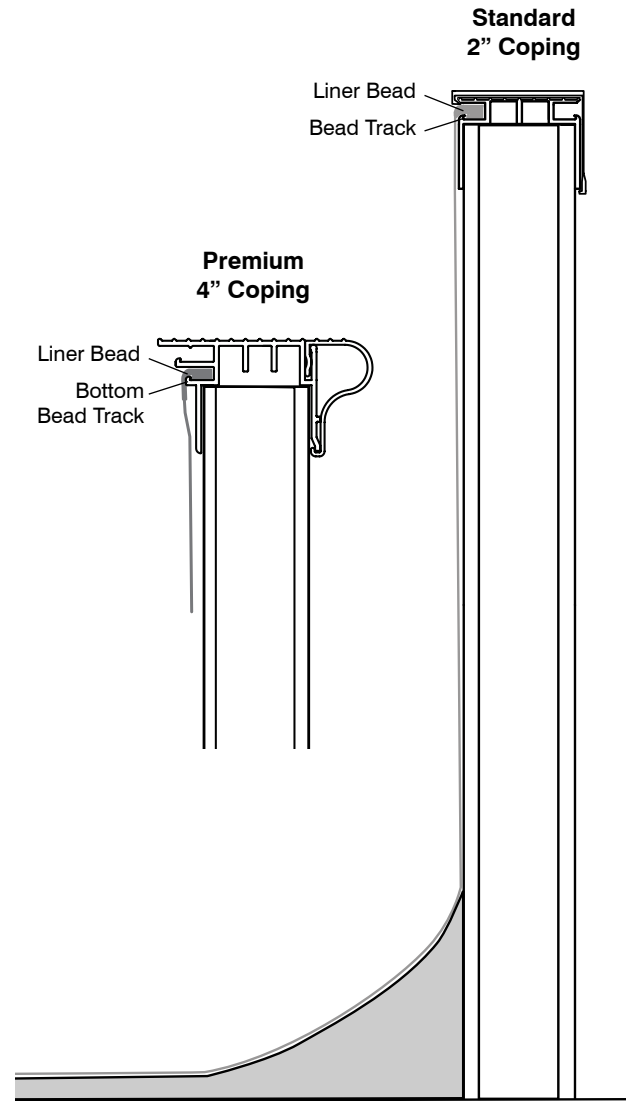

FILLING YOUR POOL

Whether you are filling the pool with your own home water source or through a water-fill service, please use the chart at right to determine the water volume requirements for your particular size pool.

Please see your pool professional for instructions on proper water testing and treatment.

Water Gallonage per Pool Size

Pool Size	Gallonage*
16'	5,514
18'	6,963
21'	9,477
24'	12,378
27'	15,666
30'	19,388
33'	23,403

*Assumes 44"-46" water depth

INSTALLING FACEPLATES

Once the water level reaches 2"-3" from the return and skimmer, install the faceplates. Carefully locate the screw holes for each opening. Once located, carefully puncture the liner with an ice pick or nail. Attach skimmer faceplate with 1" screws and hand tighten evenly in order as shown in skimmer faceplate image below. When installing return faceplate, hand tighten each screw by a half turn, alternating between each, until all are tightened evenly. This ensures uniform compression of sealing gaskets. Using a razor knife, carefully trim the liner from inside of the openings for the skimmer and return. When done, install the eyeball into the return.



Locate screw holes.



Trim liner from skimmer opening.



Skimmer faceplate installed w/screw tightening sequence.



Trim liner from return opening.



Return faceplate installed.

Note: Follow Step manufacturer's instructions for installation of step faceplate and gasket after the liner is installed and water level reaches 6-8" depth.

COMPLETING INSTALLATION

Please refer to the manufacturers' installation instructions for all other installation components. These include pump, filter, lights, and all other equipment and accessories.

ECOTHERM™ ROUND INGROUND INSTALLATION INSTRUCTIONS

INGROUND: LEVELING THE EXCAVATION

With the shape of the pool excavation marked out, its height relative to the ground must be determined. The pool should be set at a height so that rain and splash will drain away, rather than towards the pool. It is best to use a building level, transit and a measuring stick to determine the required depth of excavation. It is best to set up the transit in a location so that you can leave it in the same place for the entire pool excavation. It is best to keep the top of the pool 2"-6" above the ground at the highest point so that you are able to place your deck on undisturbed soil.

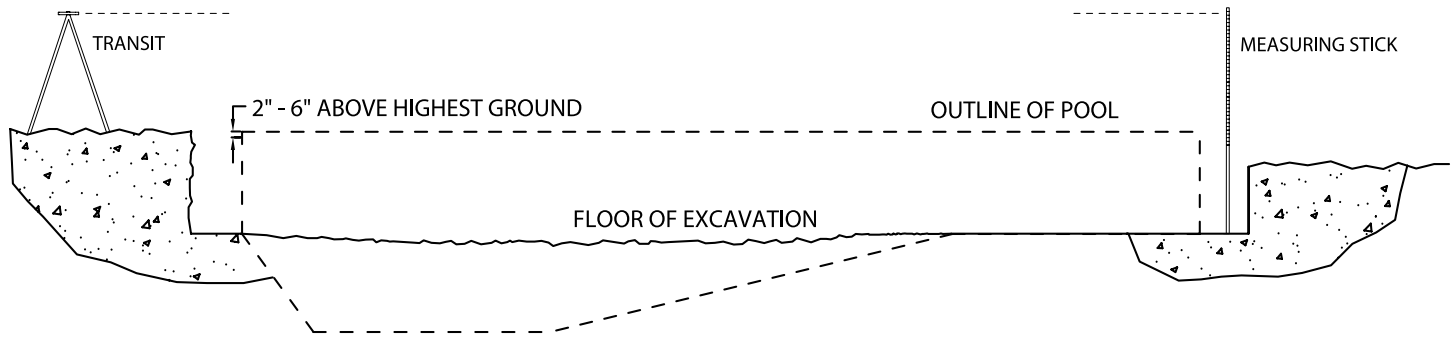

SIDE VIEW OF EXCAVATION SITE

Since the excavation will be 2 feet wider than the actual pool dimension, it is important that the excavator does not dig the 2 ft ledge around the hopper too deep. (NOTE: A 2 ft excavation is recommended for first time installations. Experienced installers may choose to use a 1 ft excavation at their discretion) A sturdier pool will result when the pool rests on undisturbed earth. It is better to have to remove an inch or two by hand than to have to build up after the excavator has gone too deep. Any voids beneath the wall panels caused by large rock removal, etc., must be filled and properly compacted.

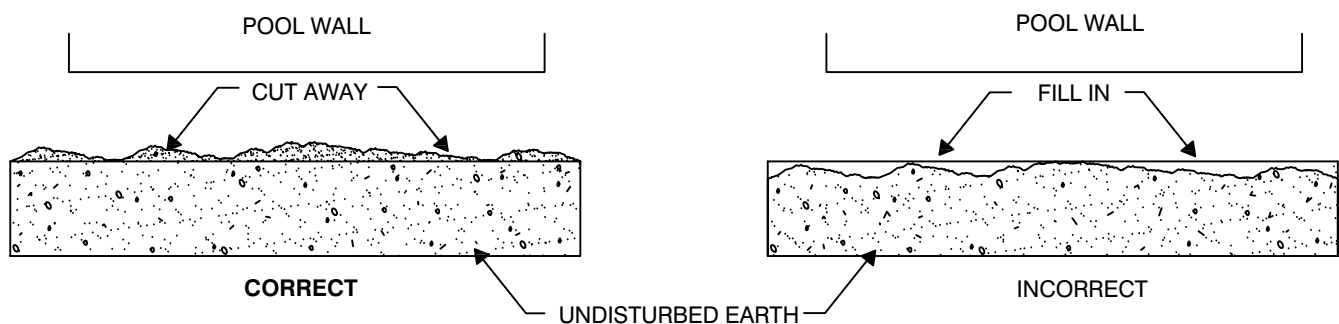

PREPARING FOR WALK-IN STEP

If steps are going to be installed, excavate a 6 foot by 10 foot area where they are to be located on the pool. Please see the dig specifications for locations of steps.

IMPORTANT NOTE: If installing steps with your Ecotherm™ inground installation, you must begin the process at the step site. Wall panels must first be mounted to the step and wall panel assembly continues from there.

INGROUND: WALK-IN STEP INSTALLATION

Each pool will have one or two panels that are shorter in length, to accommodate the step. The shorter panels should be installed on one or both sides of the step.

See chart at right to determine appropriate step type for your pool.

Step Specifications for Metric Pools

Pool Size	Step Type (52" Height)
16'	8' Radius
18'	8' Radius
21'	8' Straight
24'	8' Straight
27'	8' Straight
30'	8' Straight
33'	8' Straight

Prepare and Position Step

Install leg supports for the steps. For steps supplied by Ecotherm Pools™, instructions will be provided. If steps are purchased separately through another provider, verify compatibility by talking with a Ecotherm Pools™ representative. Be sure to check step manufacturer's instructions as the step supports will vary by manufacturer.

Position the step in the desired location. Level step, establish benchmark. The benchmark (finished height of the pool) includes the wall height, the coping and the decking (concrete, pavers, etc). Adjust height of step by aligning top of coping with top of step and plumb by checking front face of step unit with adjoining panel. See images below to determine the proper benchmark for your installation.

Once step is positioned, check levels from side to side and front to back.

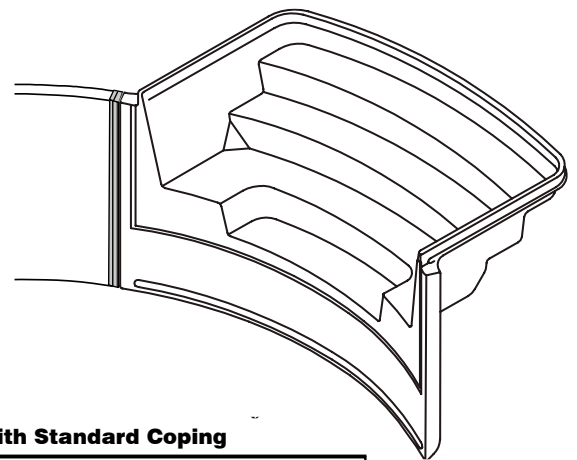

Trimline Step with RCR Coping

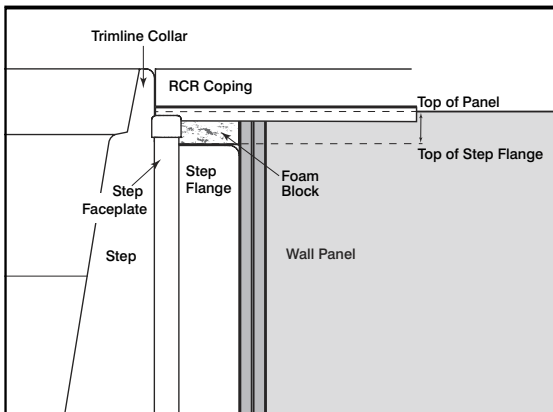

Trimline Step with Standard Coping

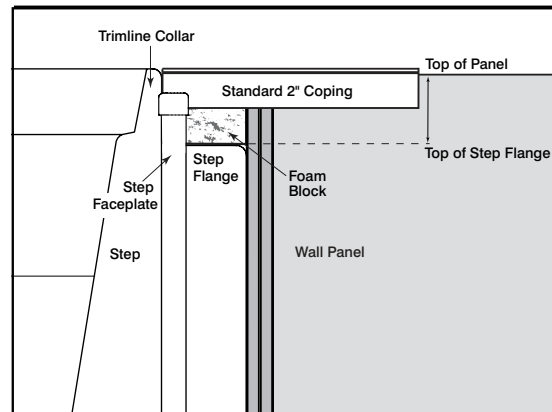

Trimline Step with Premium Coping

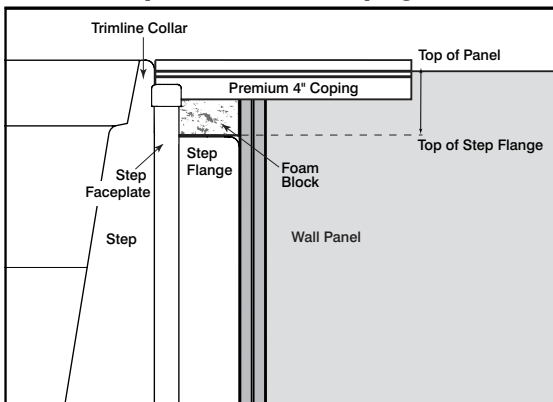

Cantilever Step with Paver Coping

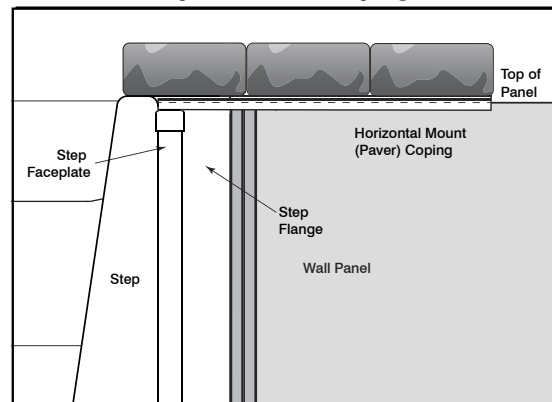

INGROUND: WALK-IN STEP INSTALLATION

RADIUS STEP TO RADIUS WALL PANEL (for pool sizes 18' and smaller)

Installation Components (item # KS-52-RWSA):

- (2) Seam Connectors
- (2) 52" Standard splines for interior side of pool
- (2) each: 40½" Extended T splines and 10" Standard Splines for exterior side of pool
- ¾" Carriage Bolts and Nuts; Backer Washers
- (2) A-Frames for connection to T Splines on either side of step

Assemble the stair adapter kit to the first pool panel with the standard 52" spline on the interior side of pool and the extended T-spline on the exterior of the panel. Position the panel butting up to the step flange and mark the location of the spline stair adapter with a marker or piece of tape.

Disassemble the adapter kit and clamp the seam connector to the step flange in line with the marked outline with vise grips or C-clamps. Using a 7/16" drill bit, drill through the step flange at the holes in the seam connector. Bolt the seam connector on to the step flange using the backer washer and nut on the inside of the step flange.

Important: Keep nuts very loose until all panels are installed.

T-spline assembly / Final adjusting

The extended T-spline is installed on the exterior side of the pool, with holes to attach the A-frame components. The 10" standard spline is installed on top of the T-spline. The 52" standard spline is installed on the interior side of the pool.

Final adjusting of the step is done after all the panels are installed and stair adapter kit nuts are tightened. Check panel joints and step ends for proper location -using the radius of the pool from the established center point of the pool.

Encase the base of the pool and step with a concrete collar. See concrete requirements on page 21.

Note: Remember to remove stair gaskets and faceplates before installing the liner.

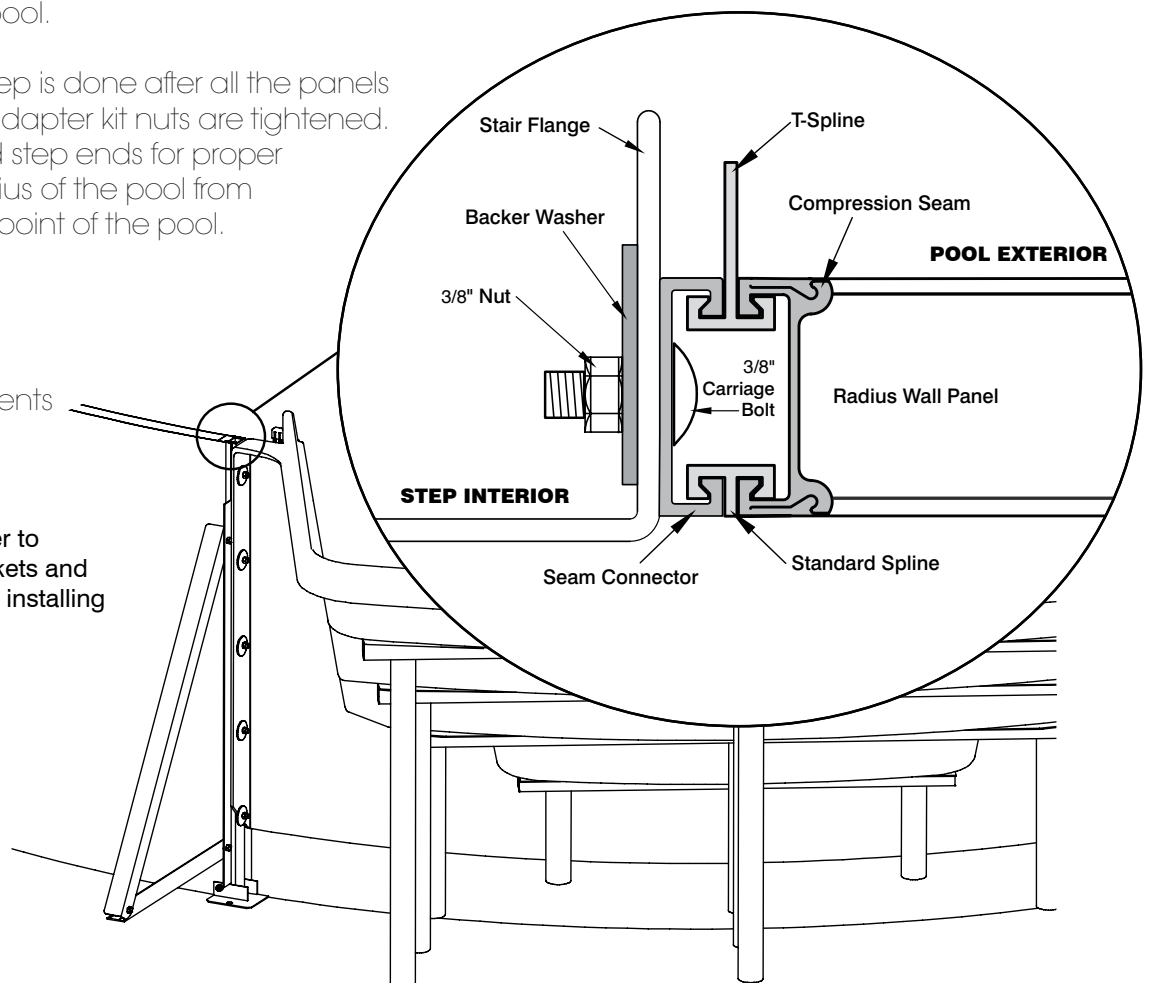

INGROUND: WALK-IN STEP INSTALLATION

STRAIGHT STEP TO RADIUS WALL PANEL (for pool sizes 21' and larger)

Installation Components (item # 2890-52):

- (2) each Male/Female Stair Connectors
- (2) 52" Standard splines for interior side of pool
- (2) each: 40½" Extended T splines and 10" Standard Splines for exterior side of pool
- ¾" HHCS Bolts and Nuts; ¾" and Backer Washers
- (2) A-Frames for connection to T Splines on either side of step

Position the female stair connector on the step flange, making sure it is level and meets the top of the pool panel. Hold in place with vise grips or C-clamps. Using a 7/16" drill bit, drill through the step flange at the holes in the female stair connector. Bolt the adapter plate on to the step flange using the backer washer and nut on the inside of the step flange. Attach the male stair connector to the female stair connector at the ball joint.

Important: Keep nuts very loose until all panels are installed.

T-spline assembly / Final adjusting

The extended T-spline is installed on the exterior side of the pool, with holes to attach the A-frame components. The 10" standard spline is installed on top of the T-spline. The 52" standard spline is installed on the interior side of the pool.

Final adjusting of the step is done after all the panels are installed and stair adapter kit nuts are tightened. Check panel joints and step ends for proper location –using the radius of the pool from the established center point of the pool.

Encase the base of the pool and step with a concrete collar. See concrete requirements on page 21

Note: Remember to remove stair gaskets and faceplates before installing the liner.

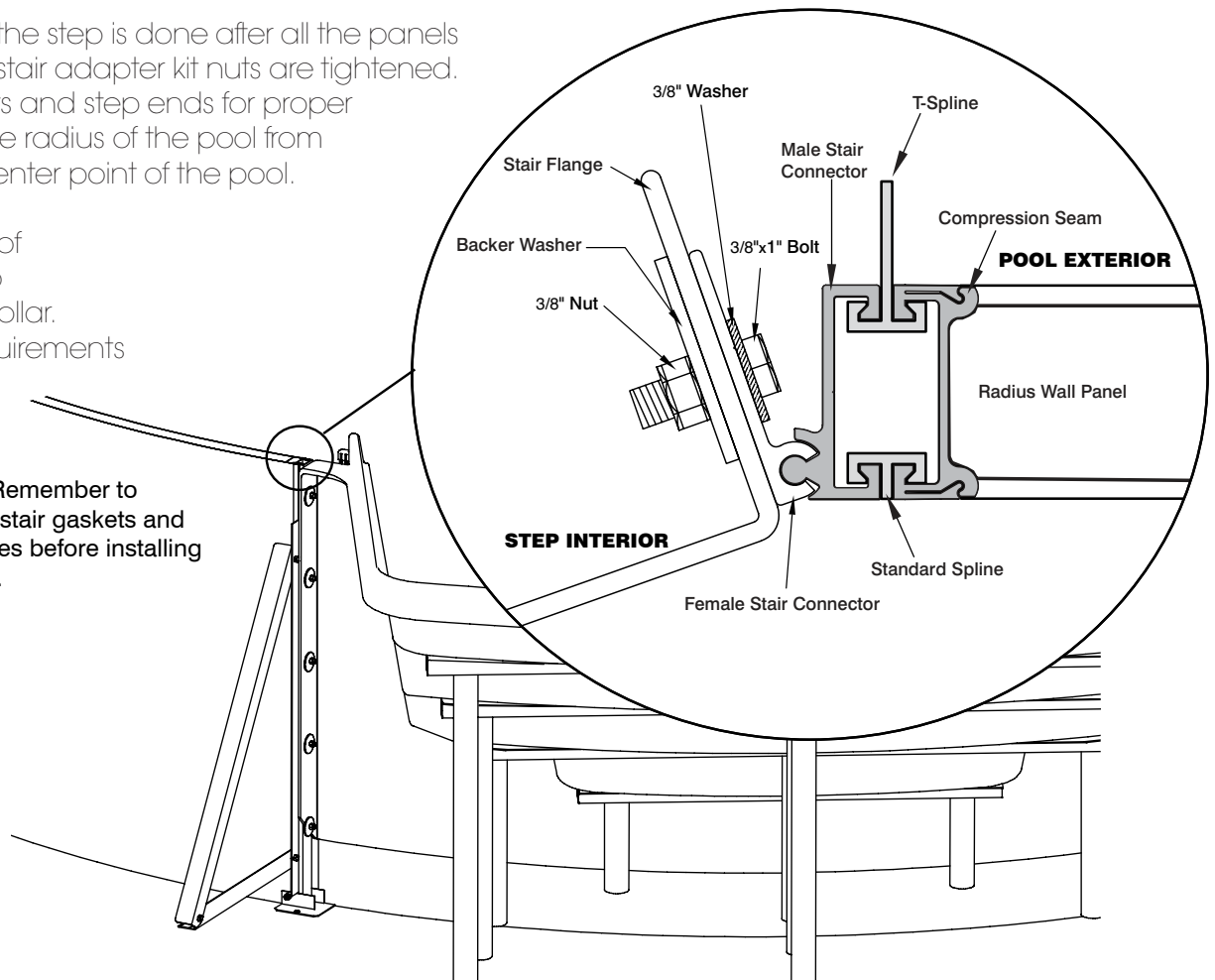

INGROUND: WALK-IN STEP INSTALLATION

Step to Radius Wall Panel

When installing a walk-in step with Standard 2" or Premium 4" plastic coping, the coping length at the step should be miter cut to follow the profile of the inside of the pool (as shown at right). Fill in gap between coping and top of step with expandable foam to prevent any debris from getting behind the liner.

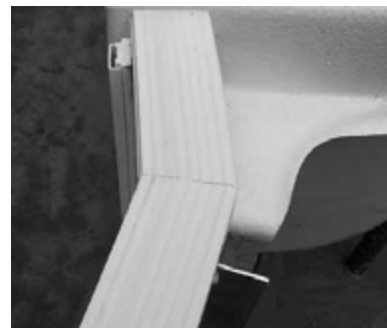

INGROUND: WALL INSTALLATION

See Page 7 for wall installation instructions.

INGROUND: CP2 OR PAVER COPING INSTALL

Wall Clips and Coping

Paver coping installation must start with Ecotherm™ Nassau wall clips. They provide a hard surface on the top of the wall to attach the coping to. Paver coping is notched to accommodate standard radii.

Place Nassau clips on the wall every 12". Do not Tek screw to the wall yet as final placement will vary with coping length.

Place Paver coping lengths on wall panel with a Nassau wall clip centered at the beginning and end of the length. Secure the wall clips to the panels and the coping to the wall clips with Tek screws on the exterior side of pool.

The next length is placed adjacent to the end of the first length, continuing around the pool. It is not necessary to leave spacing as with the white plastic coping. If you are installing a walk-in step, start at the step and continue around the pool, cutting the last length to fit.

Important: When all lengths are installed, apply a barrier between the bottom of the coping and the top of the pool wall to prevent sand and debris from getting in behind the liner. Silicone, foam sealant or duct tape can be used.

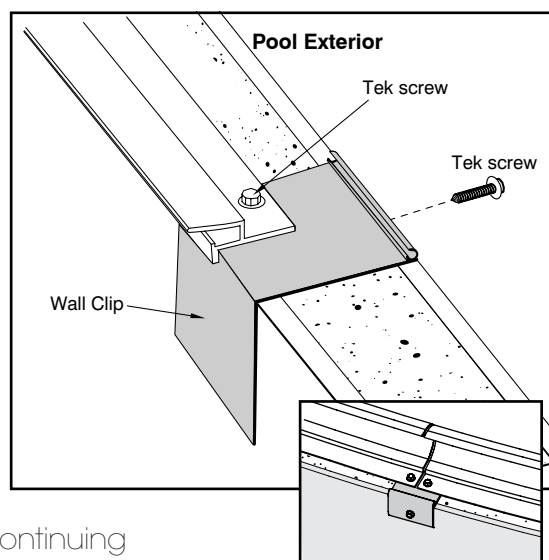

Transition with Mixed Coping

End caps are available for installation of Ecotherm™ Concrete Receptor (RCR) Coping and Ecotherm™ plastic coping combination. The end cap provides a clean finish to the concrete and fits inside the RCR coping before the lower profile of the Standard 2" or Premium 4" coping starts.

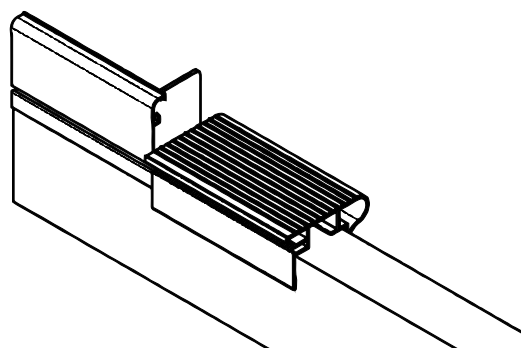

ECOTHERM™ CONCRETE RECEPTOR COPING

Ecotherm™ Concrete Receptor Coping (RCR) installation must start with Ecotherm™ Nassau Wall Clips. They provide a hard surface on the top of the wall on which to attach the coping. RCR Coping is notched to accommodate standard radii (Pre-formed 6" radius and Grecian Corners are available).

Place Nassau Clips on the wall every 12" to 18". Do not Tek screw to the wall yet as final placement will vary with coping length.

Place RCR Coping on wall panel with a Nassau wall clip centered at the beginning and end of the length. To bend notched coping, slowly pull the coping to the desired radius as you work your way down the bar. Begin securing one end of the coping with Tek screws, Nassau Wall Clips, Support Anchors and Coping Clips where needed. Use a white rubber mallet to aid in forming the coping to the final radius as you work your way down the bar. Once the desired final radius is met, secure Nassau wall clips to the pool wall and the coping to the wall clips every 12" and Support Anchors every 2½'-3'.

RCR Coping
Part # 3324-N (notched)
3324-S (straight)

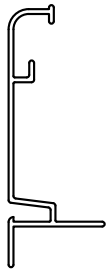

Support Anchor
Part # 3324-A

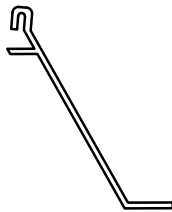

Coping Clip
Part # 3324-C

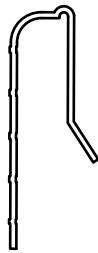

Nassau Clip
Part # 1712

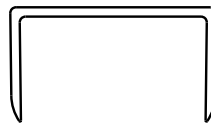

Figure A.

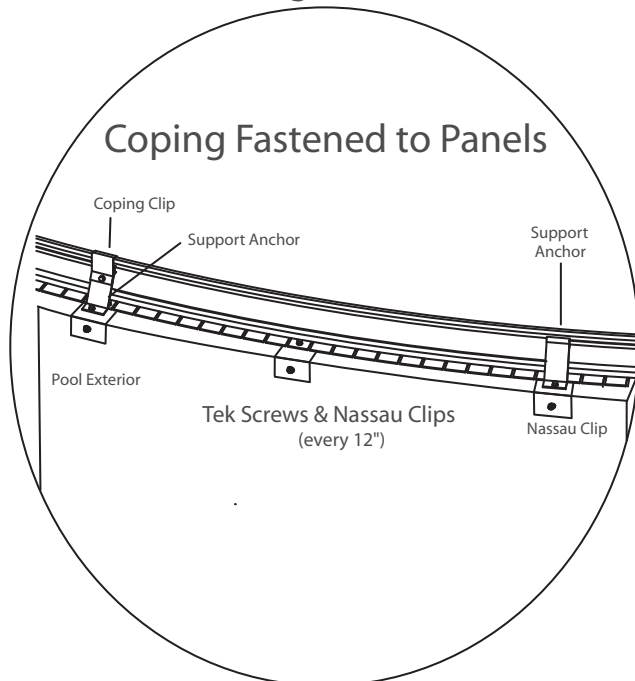
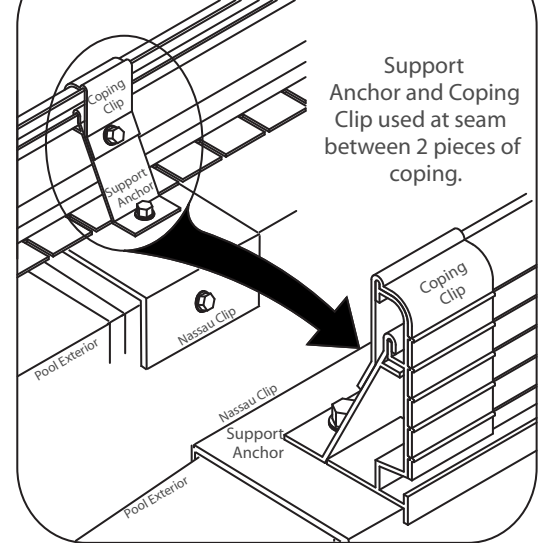

Figure B.

Covering Coping Seams



Support Anchor and Coping Clip used at seam between 2 pieces of coping.

Figure B

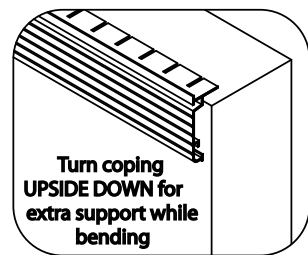
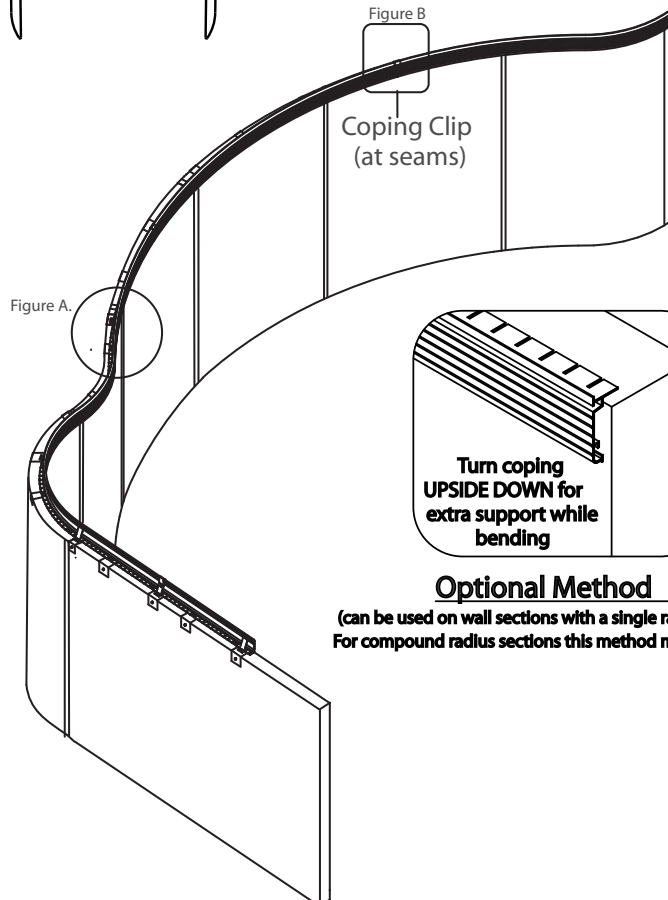

Turn coping UPSIDE DOWN for extra support while bending

Optional Method

(can be used on wall sections with a single radius to form. For compound radius sections this method may NOT work)

INGROUND: SKIMMER ASSEMBLY

Mount the aluminum skimmer plate (fig. A) to the inside pool wall and the white plastic mounting plate (fig. B) to the outside pool wall using the included nuts and bolts. Keep all connections slightly loose to ensure correct skimmer placement.

Mount inground skimmer to the aluminum skimmer mounting plate using the included screws. Now securely tighten nuts and bolts on mounting kit and cover edges of aluminum plate with duct tape.

Position one gasket (fig. C) on the sealing surface of the skimmer and secure tightly with duct tape. When dropping the liner, you may want to install the liner bead around skimmer locations last, in order to avoid disturbing gasket placement.

After liner has been installed and water level approaches skimmer, prep skimmer faceplate (fig. D) by lining up faceplate and gasket, and then carefully drive screws through faceplate, gasket, liner, interior gasket and into skimmer throat. Securing the corners first will help ensure correct placement.

As water level approaches skimmer, carefully cut out liner from inside of skimmer faceplate with sharp blade, making sure to avoid nicking gaskets.

Notes: It is recommended that 2" Schedule 40 PVC pipe be cut to size, depending on installation. Plug unused skimmer port. Place PVC pipe under skimmer body and adjust to make top of skimmer level. (fig. E)

Any gaps in the back of the white mounting plate should be covered using a spray foam filler such as "Great Stuff". After the concrete collar is poured, check level of skimmer top.

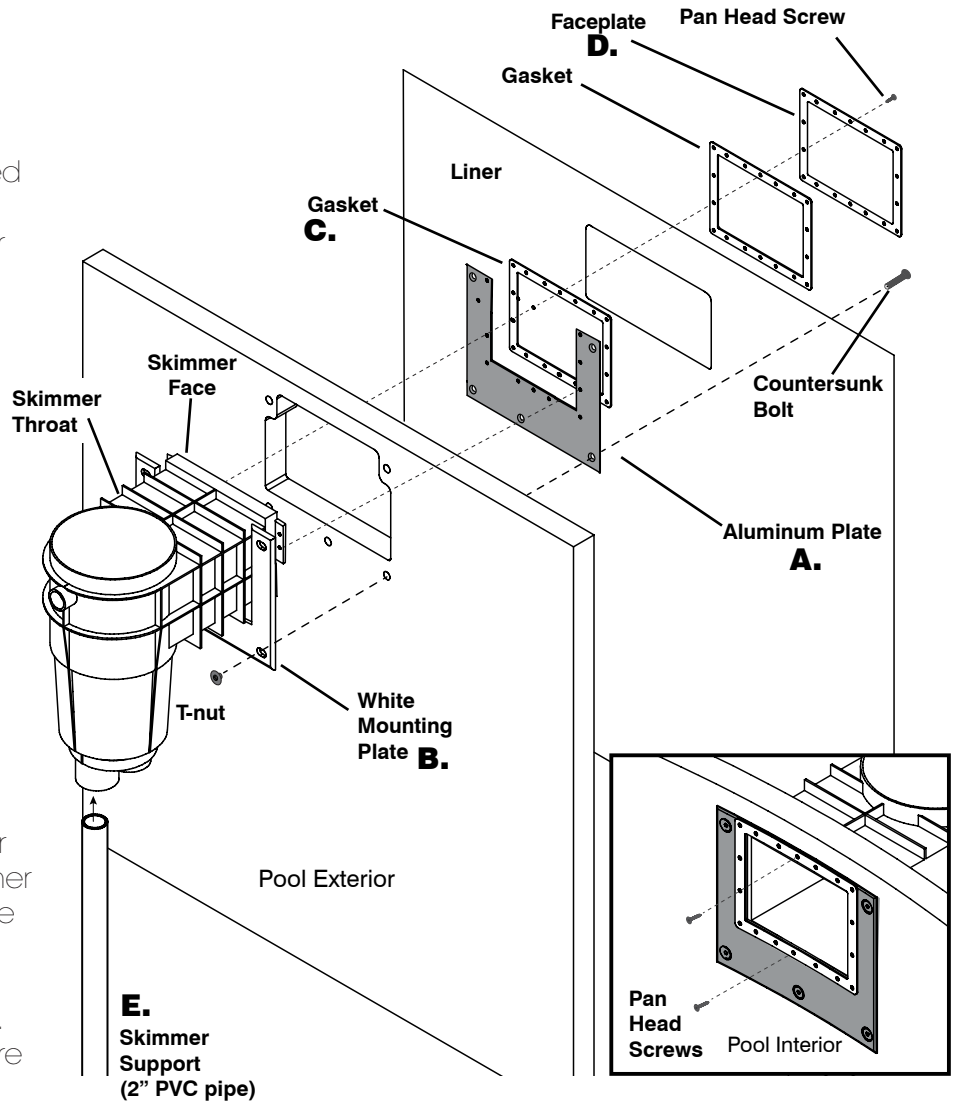

Extension Collars: Extension Collars (not included) (fig. F) are used with most inground skimmers to raise the top of the skimmer to the height of decking. The number of extension collars needed is determined by benchmark established by top of coping.

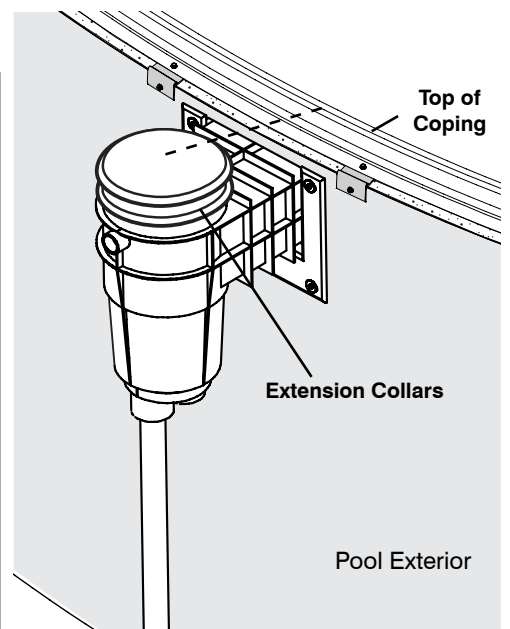
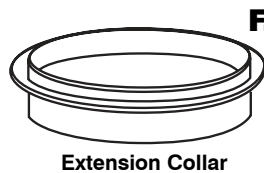

Patent Nos: 9,890,547/D837,471/D830,012/10,138,645. Other Patents Pending.

CONCRETE COLLAR GUIDE

Check with local building codes before installing your Ecotherm™ pool inground. Ecotherm Pools™ requires a minimum of 8" concrete collar around the entire pool if any point of the pool wall is 26" or greater in the ground (**fig. 2**). An example of a semi-inground pool requiring a concrete collar is shown below (**fig. 1**).

When installing an inground thermoplastic walk-in step, add 2.5 yards of concrete to the 'Concrete Requirements table' for the concrete around the step and A-frames (**fig. 3**).

Do not pour concrete directly on the pool walls. Pour concrete away from the wall and let it flow to the wall.

fig. 1

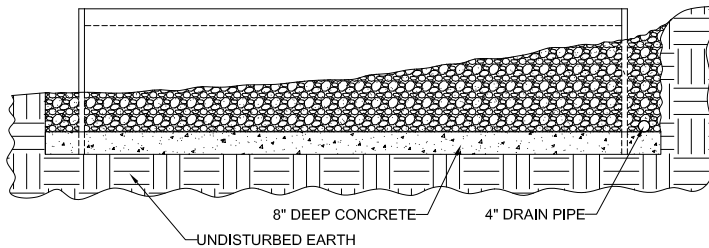

NOTE: Before pouring concrete collar, check with your electrician as he may want to bond the pool first.

fig. 2

Concrete Collar Semi-Inground

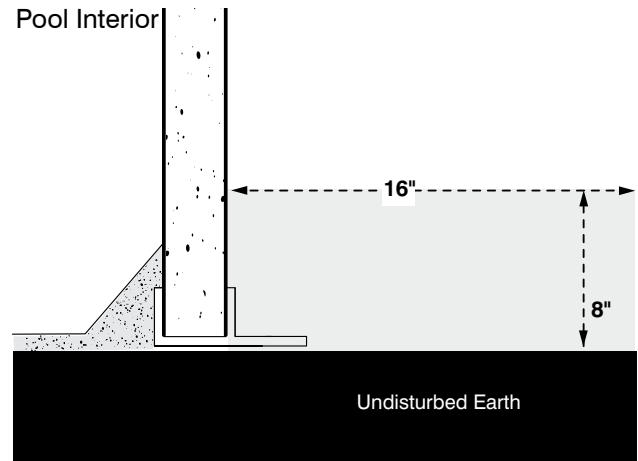
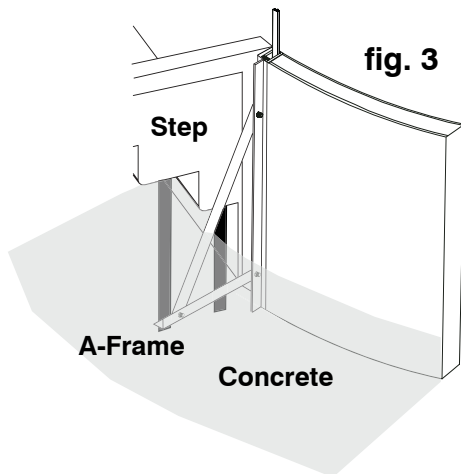

fig. 3



Note: Complete backfill is required around the step.

fig. 4

Concrete Collar at Step and A-Frame Location

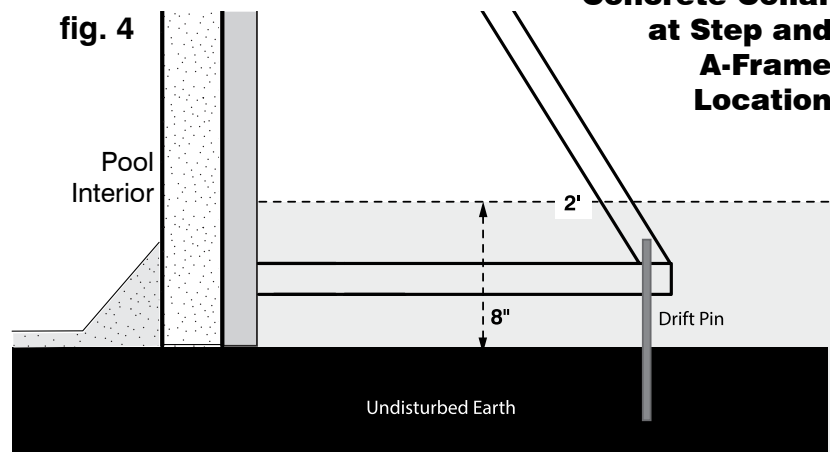

Concrete Requirements Table:

The following table describes the amount of concrete required in yards for Round Metric Pools 26" or greater inground. Add an additional 2.5 yards if thermoplastic walk-in step is included.

Size	16'	18'	21'	24'	27'	30'	33'
26" or more Backfill (Concrete Collar)	2.75 yds	3 yds	3.25 yds	3.75 yds	4 yds	4.25 yds	4.5 yds
Fully Inground (Concrete Collar)	3.75 yds	4 yds	4.5 yds	5 yds	5.5 yds	6 yds	6.5 yds

BACKFILL AND DRAINAGE

Before backfilling, check with electrician for pool bonding. Sonotubes may be installed at the time of collar pour to support the deck.

Backfill may go directly against an Ecotherm™ pool wall. Structural fill is required. **Do not use expansive soil** (e.g., clay).

For semi-inground or fully inground installations, the uphill run-off should be redirected around the pool incorporating a French drain concept using a perforated drain pipe and water relief area away from the pool and other structures.

Backfill as the pool is filling with water, manually compacting every 8"-12" (Do not use compacting machinery.) Hand backfill around skimmers, lights and inlets. Be sure that piping is buried, but not crushed.

If backfilling completely before pool is filled, the walls must be cross braced at the top, inside the pool. This is not the recommended method of backfilling your Ecotherm™ pool.

Semi-Inground

Full Inground

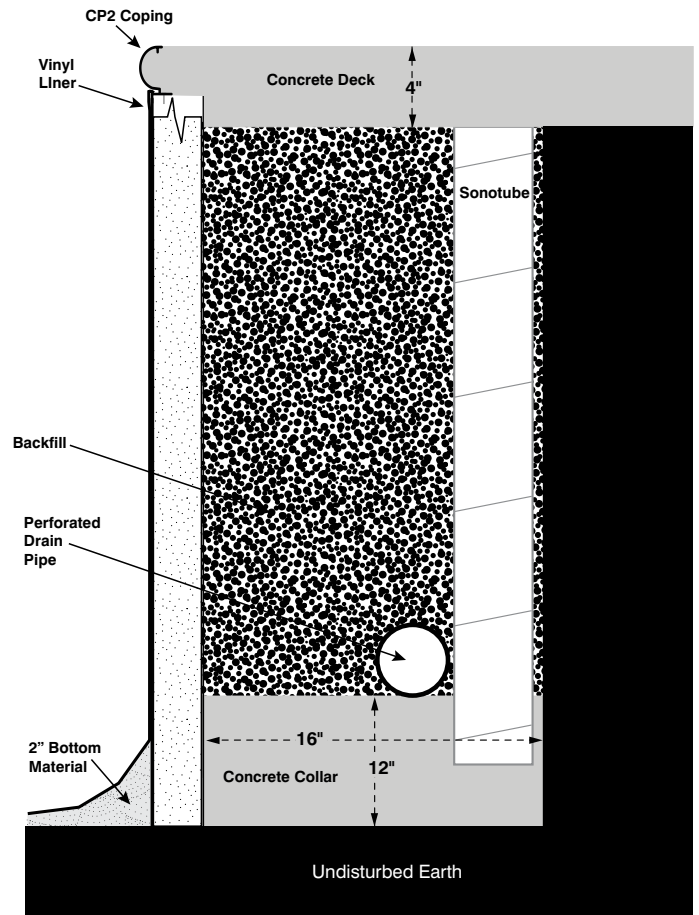
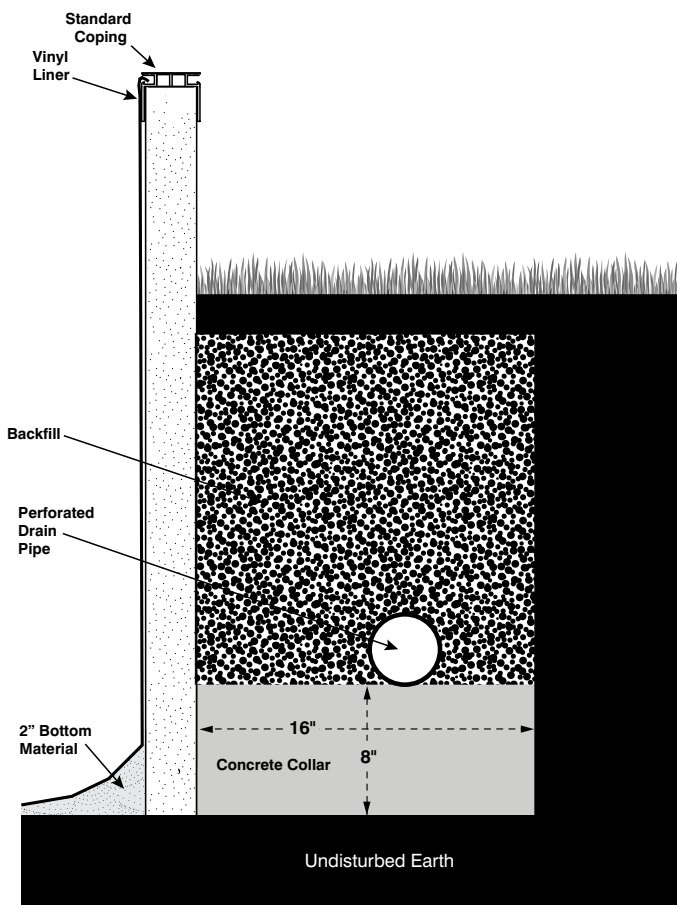

ECOTHERM™

Swimming Pools

Jump in! The Water's Warm



CAUTION: No Diving or Jumping.
Aboveground pools are designed for swimming only.

Your family's security is our priority. Always ensure the proper supervision of children when around a swimming pool.



33 Wade Rd. Latham, NY 12110
www.imperialpools.com

Code: 25102ECOR 05/26